

AIR PURIFIER OPERATION MANUAL

MODEL : WHA-200

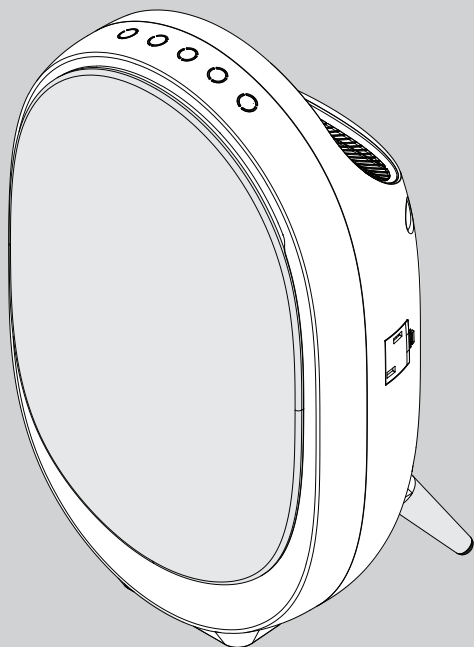

CONTENTS

- Features 2
- Name of each part 3
- Precautions 4~7
- Installation & Product Information 8
- Touch control buttons 9
- Maintenance 10~13
- Solutions to common problems 14
- Product specification 15
- Warranty 16

To keep the best working condition and guarantee long life,
read this manual carefully before you operate this equipment.



Manufacturer



161, YANGGOK-RO, YANGCHON-EUP, GIMPO-SI, GYEONGGI-DO, REPUBLIC OF KOREA

FEATURES

PURIFICATION SYSTEM

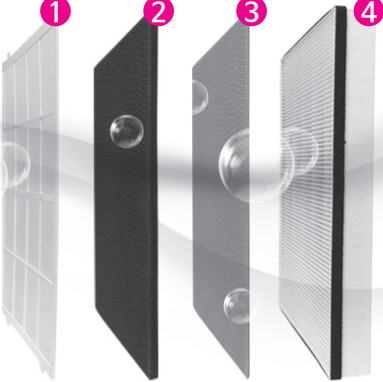

- ① **Pre filter**
 - ▶ Traps larger particles such as dust, human hair and pet dander. (Washable)
- ② **Carbon filter**
 - ▶ Traps fine dust, particles, smoke, a wide variety of gases, odors and formaldehyde to clean the air, particularly of unpleasant odors.
- ③ **Perfect filter**
 - ▶ Traps unpleasant odors and have anti bacterial effect.
- ④ **Hepa filter**
 - ▶ Traps 99.9% of microscopic particles (up to 0.3 microns), including tobacco smoke, and common allergens like pollen, mold spores and household dust.

MOOD LIGHTING AND POLLUTION INDICATING SYSTEM

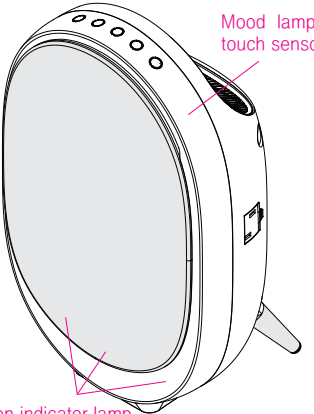

While being operated in automatic mode, dust sensor detects the air pollution status and shows the condition by four colors of pollution indicator lamp.

(Pollution) ←————→ (Clean)
 Red ▶ Purple ▶ Green ▶ blue

If you touch the Mood lamp sensor, Pollution indicator lamp will be turned into white mood light.

ONCE (Low brightness) ▶ TWICE (Medium brightness) ▶
 3TIMES (High brightness) ▶ 4TIMES (Pollution indicator lamp ON)

Without turning on the power, you can use it only for mood lamp by just touching the Mood lamp sensor.

ONCE (High brightness) ▶ TWICE (Medium brightness) ▶
 3TIMES (High brightness) ▶ 4TIMES (Mood lamp OFF)

NAME OF EACH PART

<FRONT SIDE>

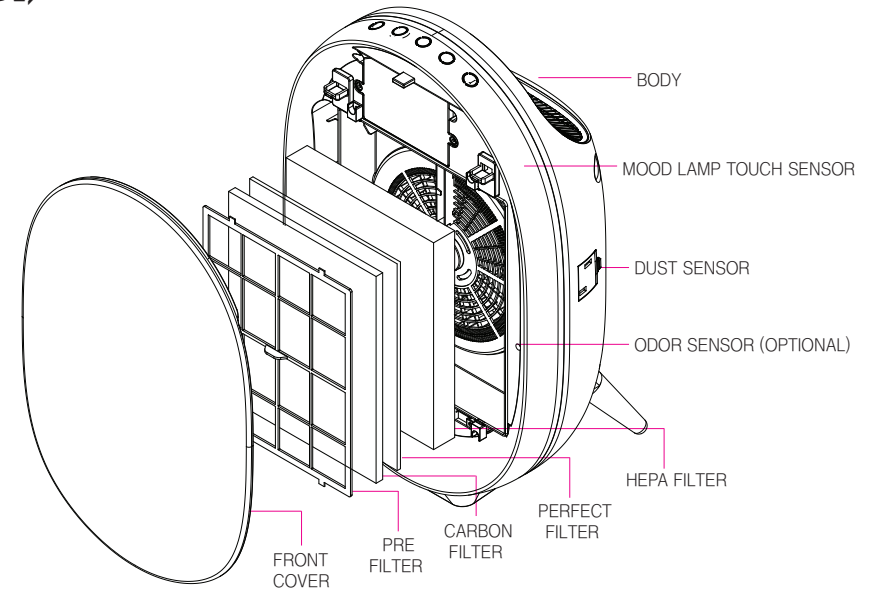

<TOP SIDE>

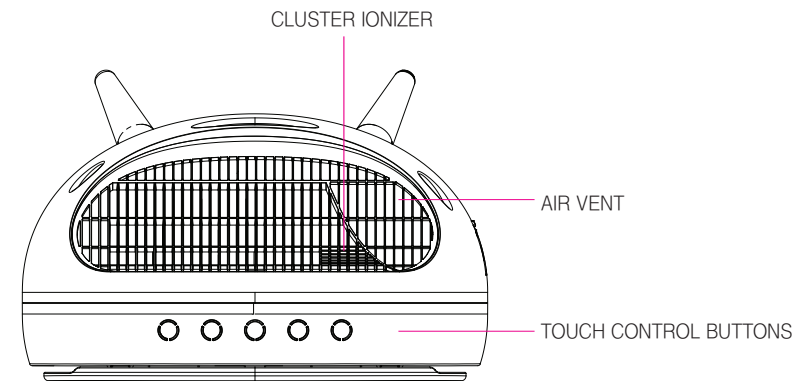

PRECAUTIONS

Read carefully following precautions to prevent unpredictable dangers and damages.

CAUTIONS Follow these instructions to avoid any risk of personal injury, property damage, electrical shocks or fire hazards.

NOTICE Failure to follow the safety instruction can lead to personal injury or property damage.

PRECAUTIONS FOR INSTALLATION

CAUTIONS NOTICE Do not operate the unit near flammable materials. (such as spray, oil, gas etc.)
▶ It may cause a fire or explosion.

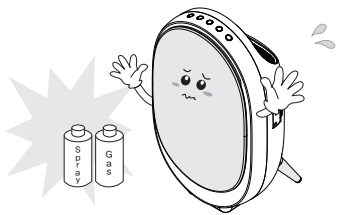

CAUTIONS NOTICE Do not install the unit at a humid place such as bath house, shower room or swimming pool.
▶ It may cause an electric shock or fire.

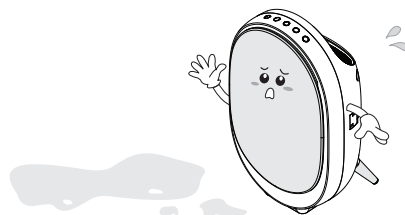

CAUTIONS NOTICE Do not place flammable substances nearby the unit.
▶ It may cause a fire.

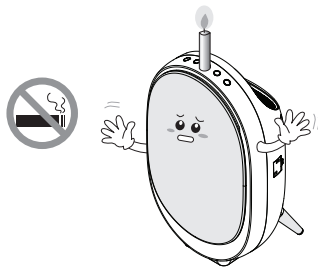

CAUTIONS NOTICE Place the unit on a level and hard floor.
▶ It may cause a malfunction or deformation of exterior.

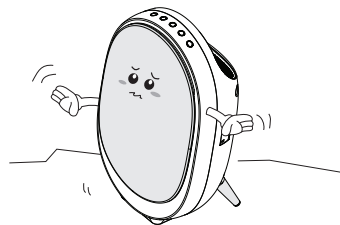

PRECAUTIONS

PRECAUTIONS FOR USE

CAUTIONS NOTICE Do not insert a plug in a loose socket.
▶ It may cause an electric shock or fire.



CAUTIONS Check the voltage rating & type of socket.
▶ It may cause an electric shock or fire.

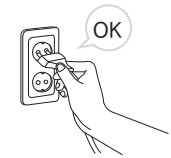

CAUTIONS NOTICE Do not replace or modify the plug.
▶ If the power cord/plug is damaged, it must be replaced by the manufacturer or a qualified technician.



CAUTIONS NOTICE Do not touch the plug with wet hands.
▶ It may cause an electric shock.

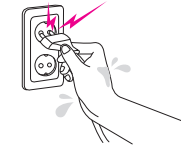

CAUTIONS NOTICE Do not unplug the unit by pulling out its power cord.
▶ It may cause electric shock or fire

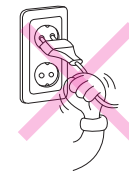

CAUTIONS Do not install the unit under the power outlet.
▶ It may cause fire.

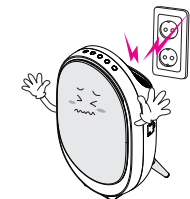

CAUTIONS NOTICE Do not severely bend the power cord or put heavy object on it.
▶ It may cause a fire.

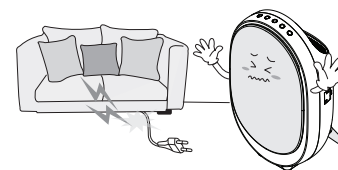

PRECAUTIONS

PRECAUTIONS FOR USE



Do not disconnect the power cord during operation.

► It may cause a malfunction or fire.

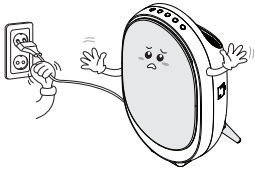

Do not touch the inner part with wet hands.

► It may cause an electric shock

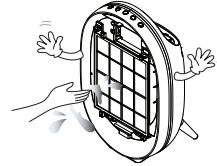

Do not operate the unit without filters.

► It may cause an electric shock

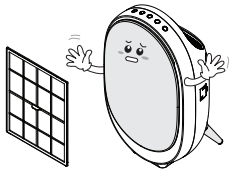

Do not spray or pour water to the unit.

► It may cause a malfunction or fire.



Do not insert anything into the air inlet or outlet.

► Especially attention to children. It may cause burns, electric shock and failure.

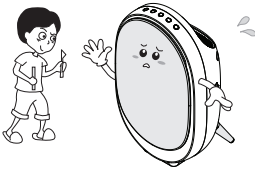

Do not allow children to play on or near the unit.

► It may cause a malfunction or deformation of exterior



Do not use the unit in a place that has much of toxic gases.

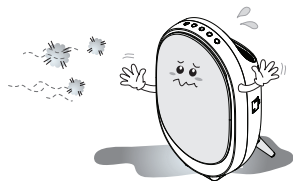

Do not use the unit in greasy or dusty places such as restaurants, kitchens or construction site.

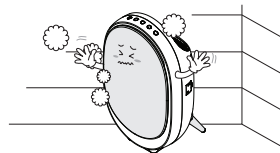

PRECAUTIONS

PRECAUTIONS FOR USE



Do not spray pesticide or flammable liquids.

► It may cause a malfunction.

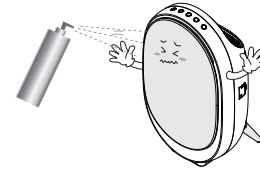

Do not place clothes or towels on top of the unit while operating.

► It may block air inlet and cause a malfunction.



Do not strike or knock the unit over.

► It may cause a malfunction

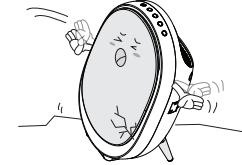

Stop using the unit if any irregular noise or smoke occurs.

Pull out the plug and then call customer service center.

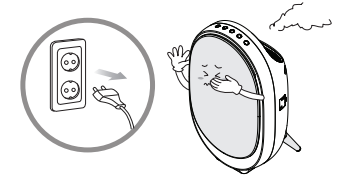

Do not put the heavy stuff on top of the unit.

► It may cause a malfunction or deformation of exterior.



Do not disassemble, repair or modify by yourself.

► It may cause a malfunction, electric shock or fire.



Do not use the unit for any purpose other than indoor air purification

► If used in the kitchen instead of ventilator, the filter replacement cycle will be shorten.

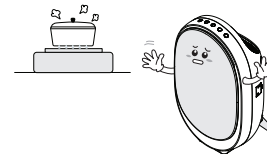

Do not use the unit in too cold or hot place.

► Optimum temperature for use is between 5°C and 30°C

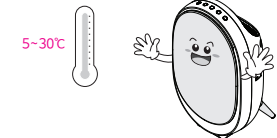

INSTALLATION

Install the unit indoor and avoid direct sunlight.

- ▶ It may cause a malfunction.

Do not install the unit in humid or unventilated place.

- ▶ It may cause an electric shock and fire.

Place the unit at least 30cm away from TV, Radio or any other electronic goods.

- ▶ It may cause a malfunction by electromagnetic interference.

Place the unit on a level and hard floor.

- ▶ It may cause noise or vibration. Place the unit at least 10cm away from the wall.

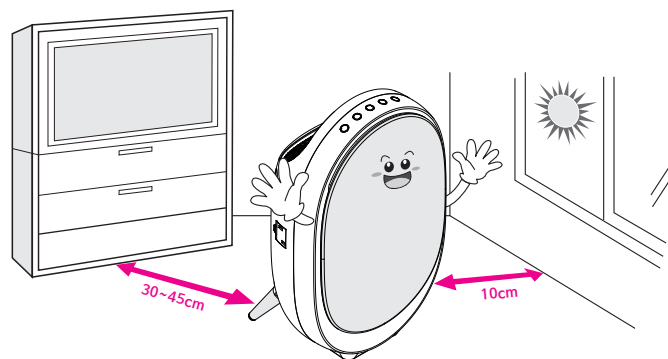

PRODUCT INFORMATION

Do not operate the unit without filters. When it has unpleasant odors, please replace filters.

- ▶ It doesn't have air purifying effect, without filters.
- ▶ Polluted filters degrade Air purification efficiency of the unit. If filters get dirty or have bad smells, please replace them.

Do not use the Air purifier to reduce odors during cooking.

- ▶ Bad odors will shorten filter replacement cycle.
- ▶ If bad smell comes from the unit during operation, Please replace the Perfect filter & HEPA filter.

While using the Air purifier, please close the window and door.

- ▶ If the windows and doors are open, the air purifier will be less effective.

TOUCH CONTROL BUTTONS

TOUCH CONTROL BUTTONS



SLEEP MODE



TIMER



POWER (LOCK BUTTON)



FAN SPEED (AUTOMATIC OPERATION)



CLUSTER IONIZER (FILTER REPLACEMENT INDICATOR)

	POWER (LOCK BUTTON)	Power ON and OFF / 'LOCK' setting
	FAN SPEED (AUTO)	Fan speed control (LOW, MED, HIGH, TURBO, AUTO)
	CLUSTER IONIZER (FILTER REPLACEMENT INDICATOR)	IONIZER ON/OFF(Indicating Filter replacement cycle)
	TIMER	OFF Timer setting
	SLEEP MODE	SLEEP MODE operation setting

HOW TO CONTROL

POWER (lock button)

- If touching the power button, the operation will start with 'DING' sound and low fan speed.
- If touching the power button more than 3 sec, the control buttons will be locked. (Only one lamp on the power button is turned on.)
- If touching again the power button more than 3 sec, the control buttons will be unlocked.

FAN SPEED (AUTOMATIC OPERATION)

- Each time the button is touched, the Fan speed changes.
- Location of LED lamps around the button will be changed according to fan speed.

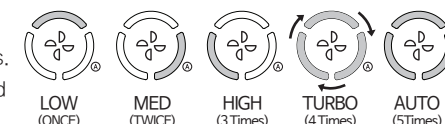

AUTOMATIC OPERATION FUNCTION (3 LED LAMPS AROUND FAN SPEED BUTTON WILL LIGHT UP)

- When the auto mode is set, the dust sensor controls fan speed depending on the air quality.
- According to the air condition, the color of pollution indicator lamp will be changed.



TIMER

- Each time the button is touched, the OFF TIMER is set after 2,4 or 8 hours.

SLEEP MODE

- The lowest fan speed & brightness of lamps will be set.

CLUSTER IONIZER

- Cluster ionizer cleans the air by sending molecular particles into the room. Those particles, also known as ions, attach to oxygen in the air to create a negative charge.

FILTER REPLACEMENT INDICATOR

- When it's time to change HEPA filter, 3LED lamps around cluster ionizer button is blinked.
- After filter replacement, touch the button for more than 3 sec to reset.

MAINTENANCE

BEFORE FILTER REPLACEMENT

When the filter replacement cycle indicator is blinking, please replace the filter set.

The filter replacement cycle is about one year.

※ The filter replacement cycle may vary depending on use environment.

The filter replacement indication is on the basis of HEPA filter's lifespan.

Please replace the other filters referring to page13.

- Be sure to use genuine filters.

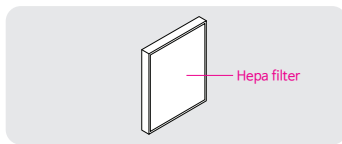

- Please be sure to disconnect the power plug before replacing filter.
- Please take off plastic packaging of filter set. If don't, it may cause fire or deformation of product.
- After replacing filters, please touch the cluster ionizer button for more than 3 sec until it makes 'DING' sound to reset.

HOW TO REPLACE FILTER

1

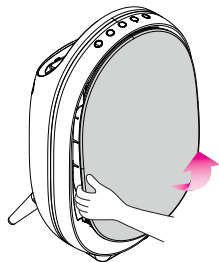

Hold lower part of the front cover and pull it out.

2

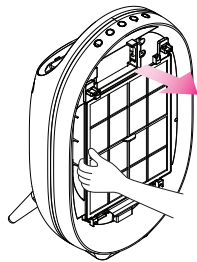

Hold grip of Pre-filter and pull it out.

MAINTENANCE

3

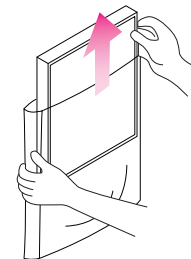

Take off the plastic packaging of each filters.

4

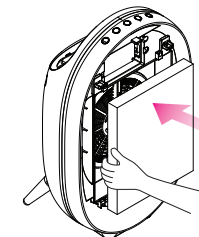

Perfectly insert the new filter to the end of frame.

5

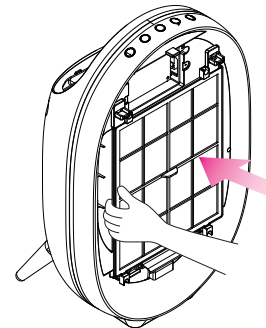

Fit the 4 hooks of Pre-filter into 4 slots of body

6

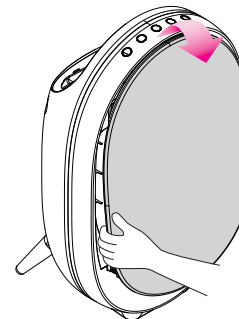

close the front cover.

CAUTION • BE SURE TO USE GENUINE FILTERS.

MAINTENANCE

DUST SENSOR CLEANING

1

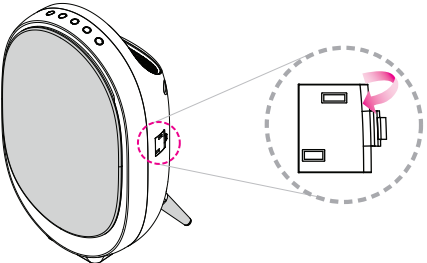

Open the Dust sensor cover on the right side of the unit by pulling out.

2

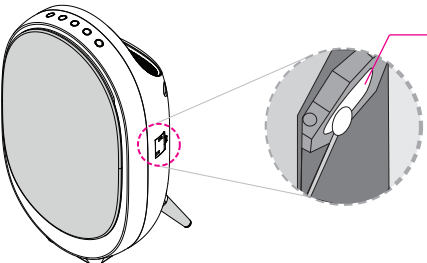

DUST SENSOR

Use a wet cotton swab to clean the dust sensor and wipe again using dry cotton swab to remove moisture.

3

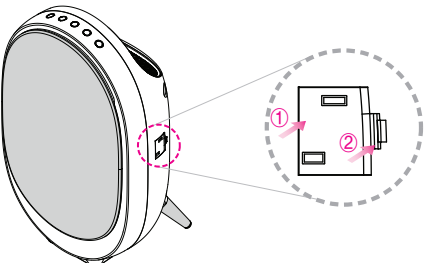

After fitting two hooks on the left side of the cover into two slots in sensor part, press the ①&② part in numerical order.



- Do not clean the sensor with volatile substances other than water.
- If Dust sensor still has the foreign substance, the air pollution indicator lamp won't be changed. So, please clean the sensor again.
- Clean the sensor every 6month. But the cleaning cycle could vary depending on the use environment.

MAINTENANCE

FILTER CLEANING & REPLACEMENT CYCLE

Kind of filter	Replacement Cycle	Cleaning Cycle	Cleaning method
PRE FILTER	semi-permanent	About 1 month	Use the Vacuum Cleaner or brush. If heavily polluted, please wash with a neutral detergent.
HEPA FILTER	About 12Month	DO NOT WASH	
CARBON FILTER	About 8Month		
PERFECT FILTER	About 4Month		

EXTERIOR CLEANING

- Clean the exterior with a dry cloth
- clean the front cover with a vacuum cleaner or dust brush about once a month.

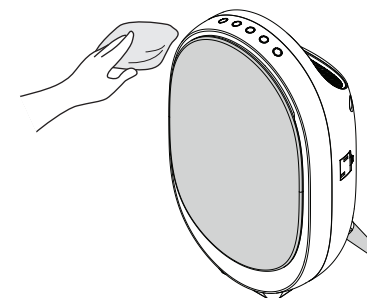

- Turn off the Air purifier and pull the plug out before performing any maintenance.
- Do not use Benzene, Alcohol, or any other Volatile substances.

SOLUTIONS TO COMMON PROBLEMS

Check the followings before asking service center.

State	Check	Solution
The unit does not operate	• Is the plug correctly inserted?	• Correctly insert the plug into the socket.
	• Check power outage	• Use the Air purifier after checking power supply.
Automatic mode does not work	• Is the plug correctly inserted?	• Collectly insert the plug. Then set the Automatic mode again.
	• Check if the Auto mode is set.	• Set the Automatic mode.
RED light of pollution indicating lamp does not change	• Check the dust sensor	• Clean the dust sensor. • If still on RED light, please call customer service center.
Strong Noise and vibration	• Is the unit installed on uneven floor?	• Install the Air purifier on even floor.
Plug& outlet is getting hot	• Check the power plug.	• Correctly insert the plug into the socket.
Strange odors	• Is the unit used in a smelly or smoky place?	• Clean the inlet AIR VENT and PRE-FILTER. • Replace The Perfect filter.
The air is not cleaned. The air flow is weaken	• Check the filter replacement indicator.	• Clean the Pre-filter. • Replace the HEPA filter.
Strange indication	• Check if the LED lamps around the fan speed button flickers with 'Ring-Ring' sound.	• It has problem. Call customer service center.
Strange sounds	• Check noise	• While the cluster ionizer is being operated, it could make some noise.

PRODUCT SPECIFICATIONS

Product Name	Air Purifier
Model No.	WHA-200
Rated Voltage	220V / 60Hz
Power Consumption	34W
Air Purifying Available Area	34 m ²
Dimension	430(W) x 280(D) X 642(H)mm
Weight	6.6kg

PRODUCT WARRANTY

Product	Model	<input type="checkbox"/> WHA-200	
	Date of Manufacture		
Date of Purchase	Year	Month	Day
Customer's Name			
Dealer's Name			

WARRANTY GUIDE

1. The warranty period is 12 months from date of purchase.
2. In following case, the product will be repaired at cost.
 - a) After expiry of free warranty period.
 - b) Malfunction of caused by careless or abnormal use.
 - c) Malfunction of caused by natural disaster.
 - d) In case this manual has been lost.

 **WONBONG Co., Ltd.**

Head Office & Factory

161, Yanggok-ro, Yangchon-eup, Gimpo-si,
Gyeonggi-do, Korea

Tel : 82-31-987-7101
Fax : 82-31-989-6109